

CIRTEM⁺

POWER OPTIMISED



January 2025

Power electronics
System engineering
R&D teams

Objective : Create **power converters** and **global solutions** for
an **optimized management** of **electric energy flow**



CIRTEM - Sainte-Foy-d'Aigrefeuille (Toulouse)

Manufacturing

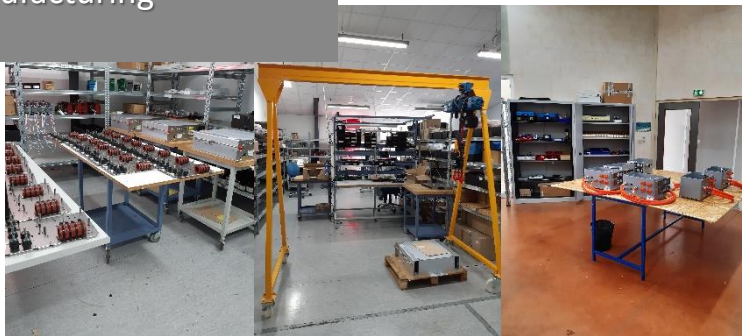

- ✓ Turn over 2024 : €6M
- ✓ 53 employees, including 28 R&D
- ✓ Premises 2 400 m²
- ✓ **Small & Medium volumes**
- ✓ Location Toulouse area
- ✓ ISO 9001 (2021)
- ✓ Innovative applications
- ✓ Demanding markets

French Clusters

MEMBRE DE

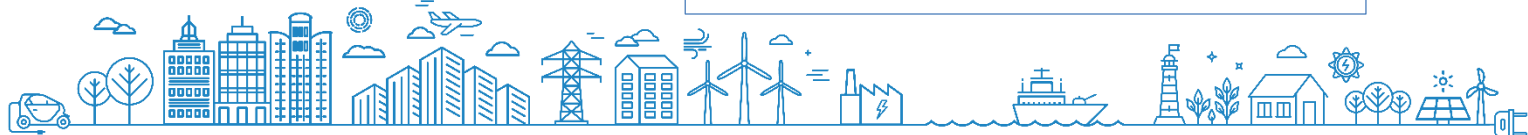

CIRTEM - POWER ELECTRONICS SPECIALIST

Our plant – Our Team



- ✓ New building 2025 - 3 200 m²
- ✓ SMD line
- ✓ Automated assembly lines



History

Customers - Company key events

Mobility – Defence - Energy
E/E Systems & Products

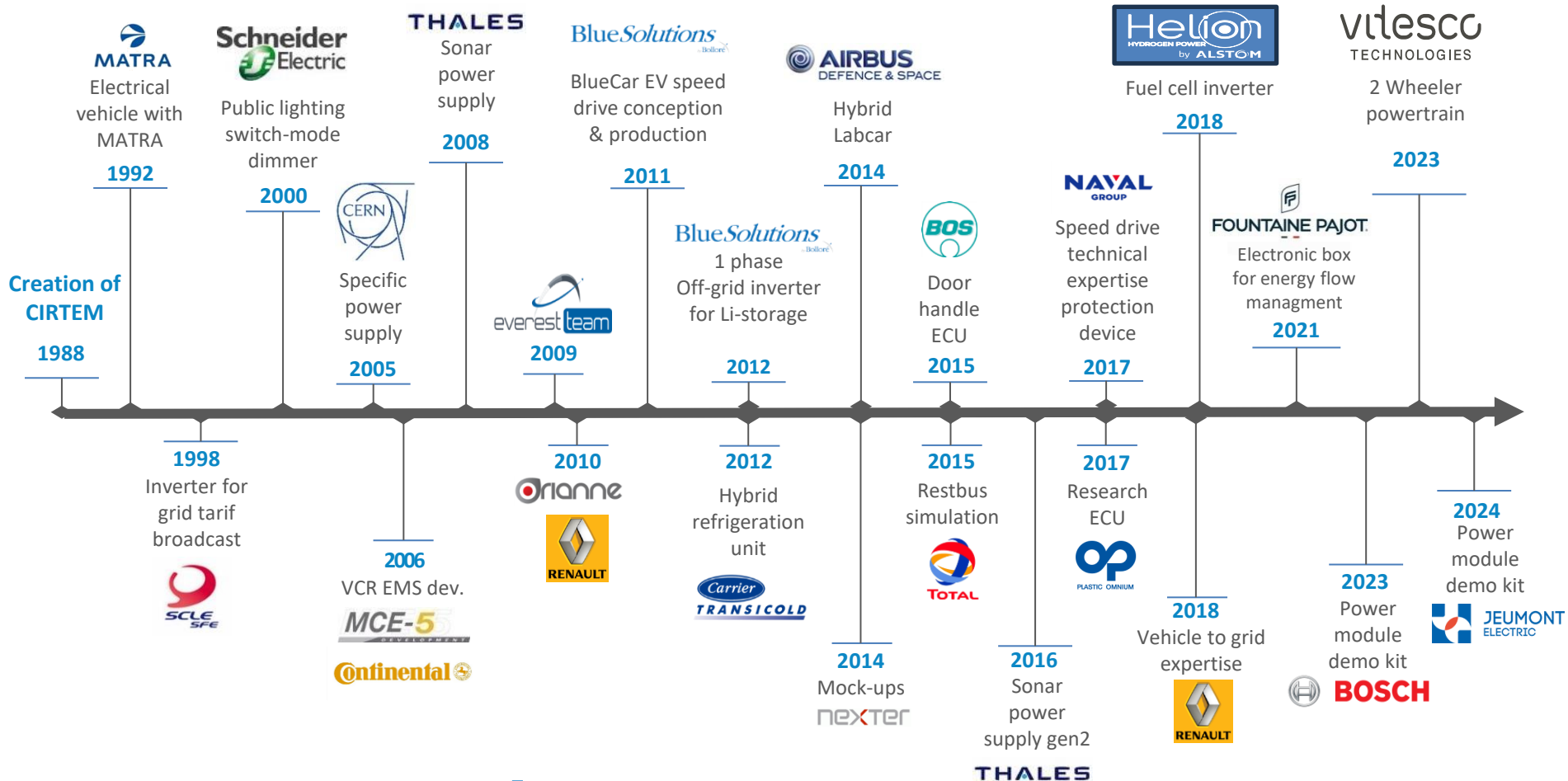

Markets

Multi-sectorial approach



Mobility 50%

Speed drives

DC/DC

OBC & CHARGERS

ICE & Hybrid Control



Defence 25%

Onboard network

Powertrain

Storages

Protections



Industry 10%

Process Power Supply

Ozonation

HV power supply

Induction



Electric infrastructures 15 %

Smart Grids

Micro Grids

Railway

Fast charging

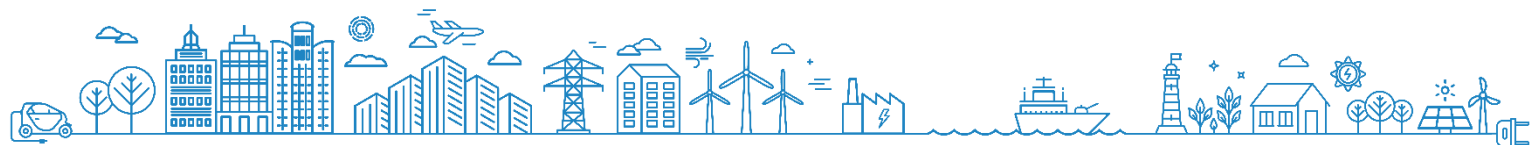

Power Converters and Electronic Equipments

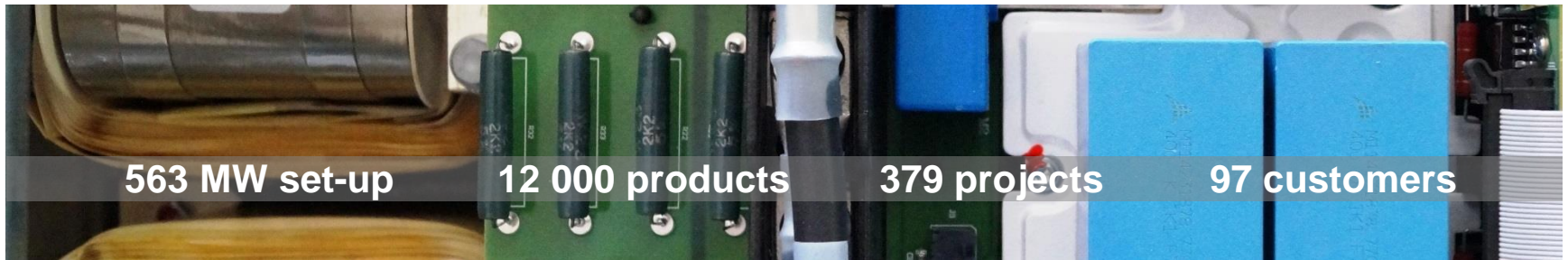
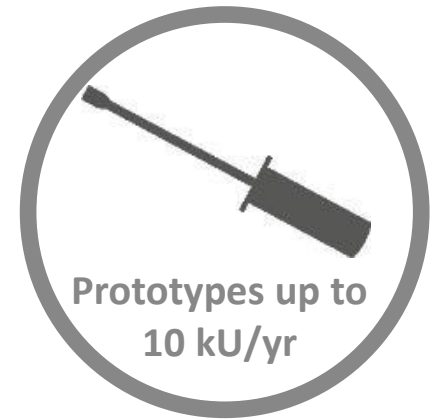

Mission
Added value

System Engineering

Architecture optimization
Tailored help
Preliminary specification

Development

Simulation
Power design
Mechatronics
Software
Qualification

Production

Small and mid series
One-shot product
Prototypes

Build-to-print

Specialized subcontracting
Test bench development



Pre-study

Technical feasibility
Budgetary cost
Detailed specification

Industrialization

Optimized supplies
Semi-automated assembly
Automated testing

MCO

Obsolescence monitoring
Redesign
Components storage

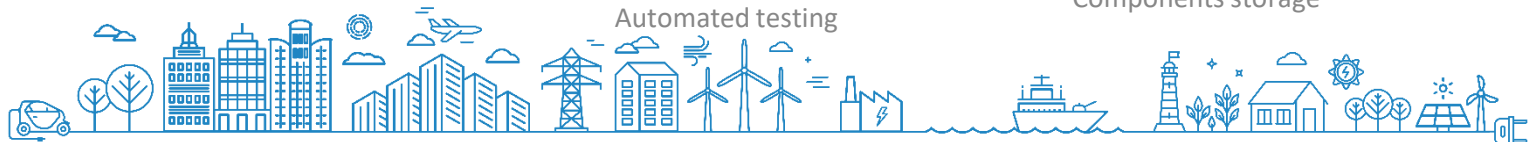

System Expertise

Full V-Cycle Coverage

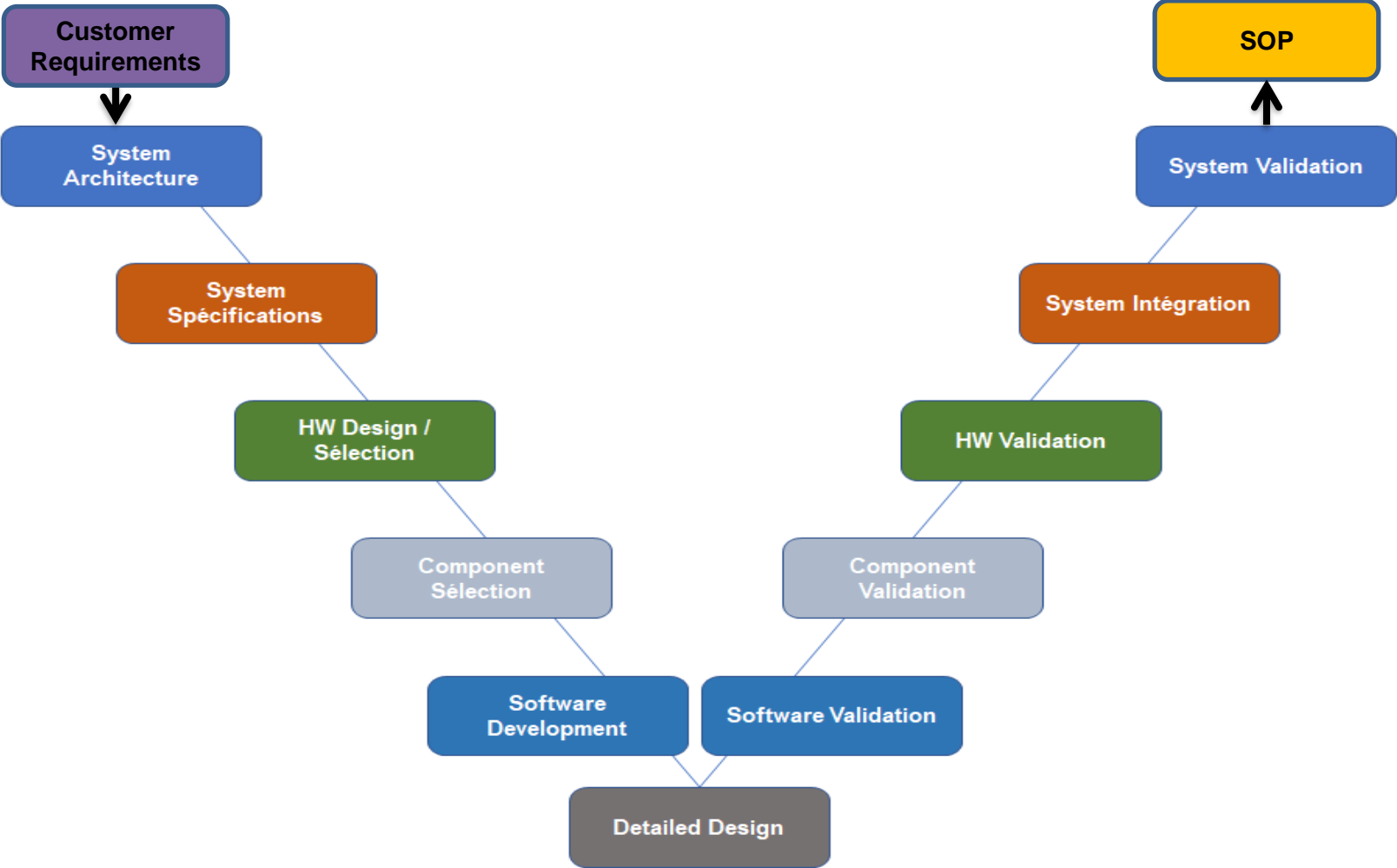

Development process HW Preliminary Design

CIRTEM –INVERTER

Preliminary Design

T1 = T0 + 4 months

System architecture

Electric functional diagram

Main component selection

Draft PCB Design (ALTIUM 3D)

Thermal simulation (Solidworks)

Functional simulation (PSIM)

DC Bus design concept

DC Bar calculation simulation (JMAG if needed)

Draft 3D (Solidworks)

Test specification

Test bench planing

Detailed specification (SW, HW)

PDR

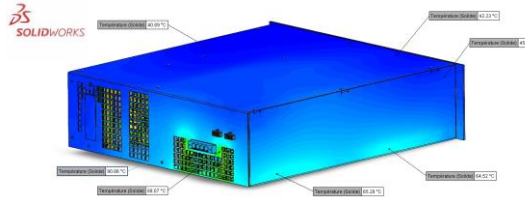

JMAG

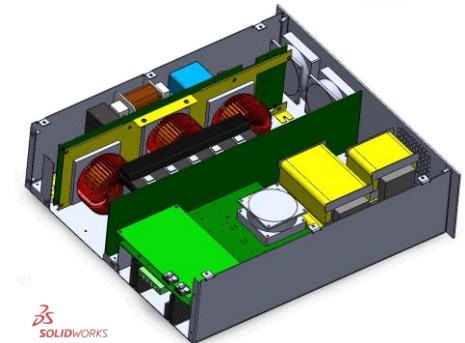
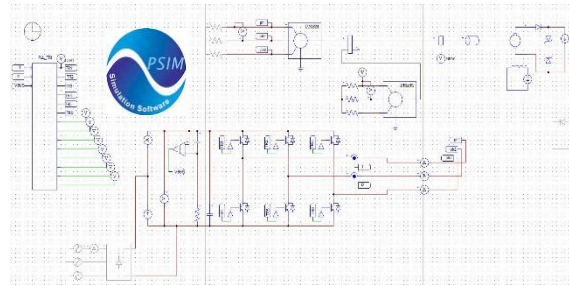
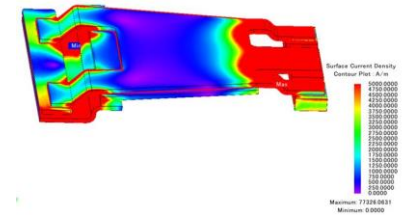

Critical Design T2 = T1 +8 months

Mechanical design – Part development, finalize mechanical integration

3D & 2D drawings: cooling plate, DC Bus bar, housing, overall integration, specific components (coils, transformers)

Electronic schematics & lay-out:

Power electronics

Control board

Interface board between control board & Power electronics

SW Coding

Supplier RFQs

Product specification: assembly guide & user guide

CDR

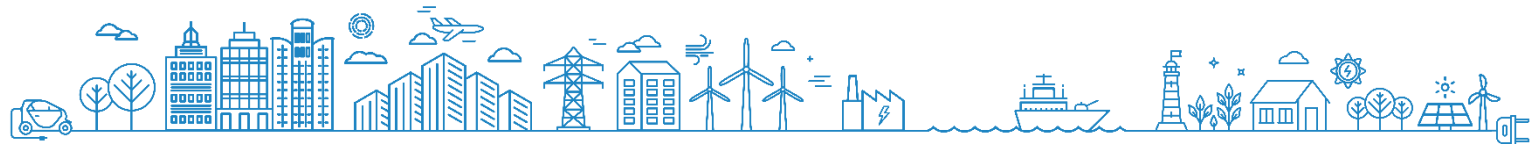

CIRTEM –INVERTER

ASSEMBLY, INTEGRATION, VALIDATION & TUNING

Mechanical & specific part incoming qualification

First Prototype Assembly

Product validation

System integration, performance validation

(Power test bench, motor test bench)

INDUSTRIALISATION

End of Line Test bench

Test programs (ERP)

Manufacturing process validation

CIRTEM Part Approval documents

Customer Part Approval documents

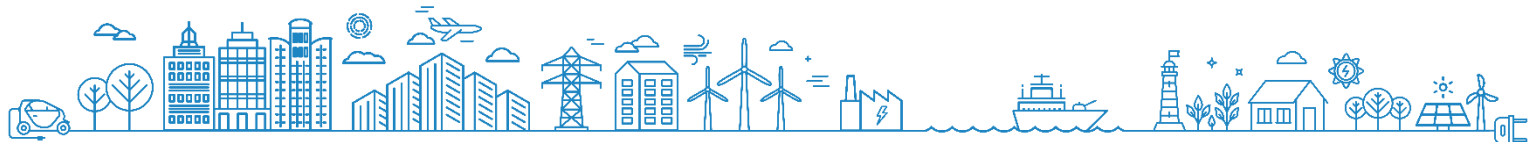

- Cirtem is ISO9001:2015 compliant
- Software development process is integrated to product development process
- Full process is defined in PRC04_148 / 149. It follows V-cycle, with following steps :

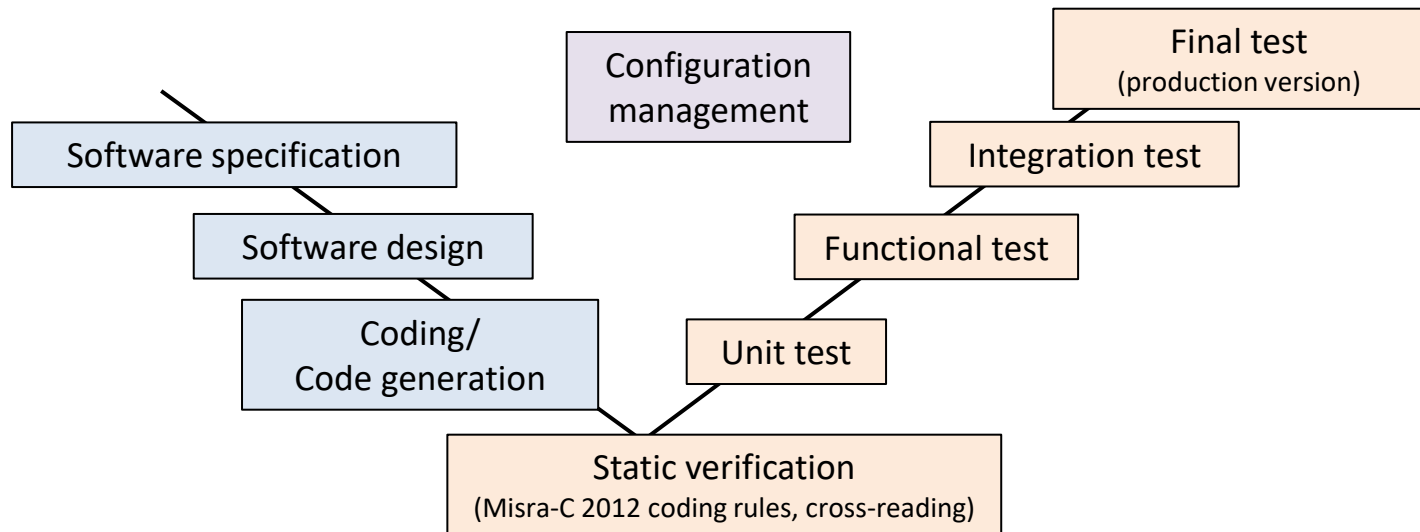

- Process application is tailored to fit project needs (R&D to industrial)
- Development process evaluated DO178 DAL D/C (defense customer evaluation)

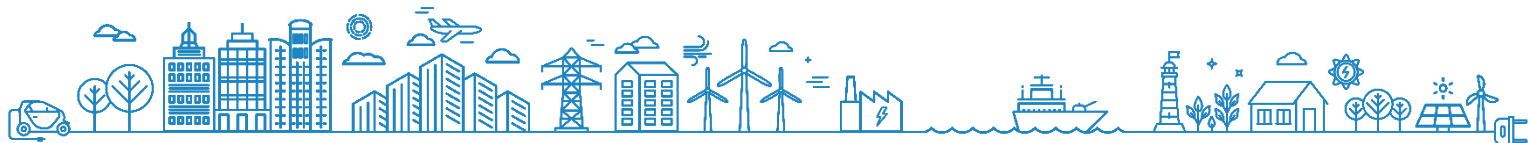

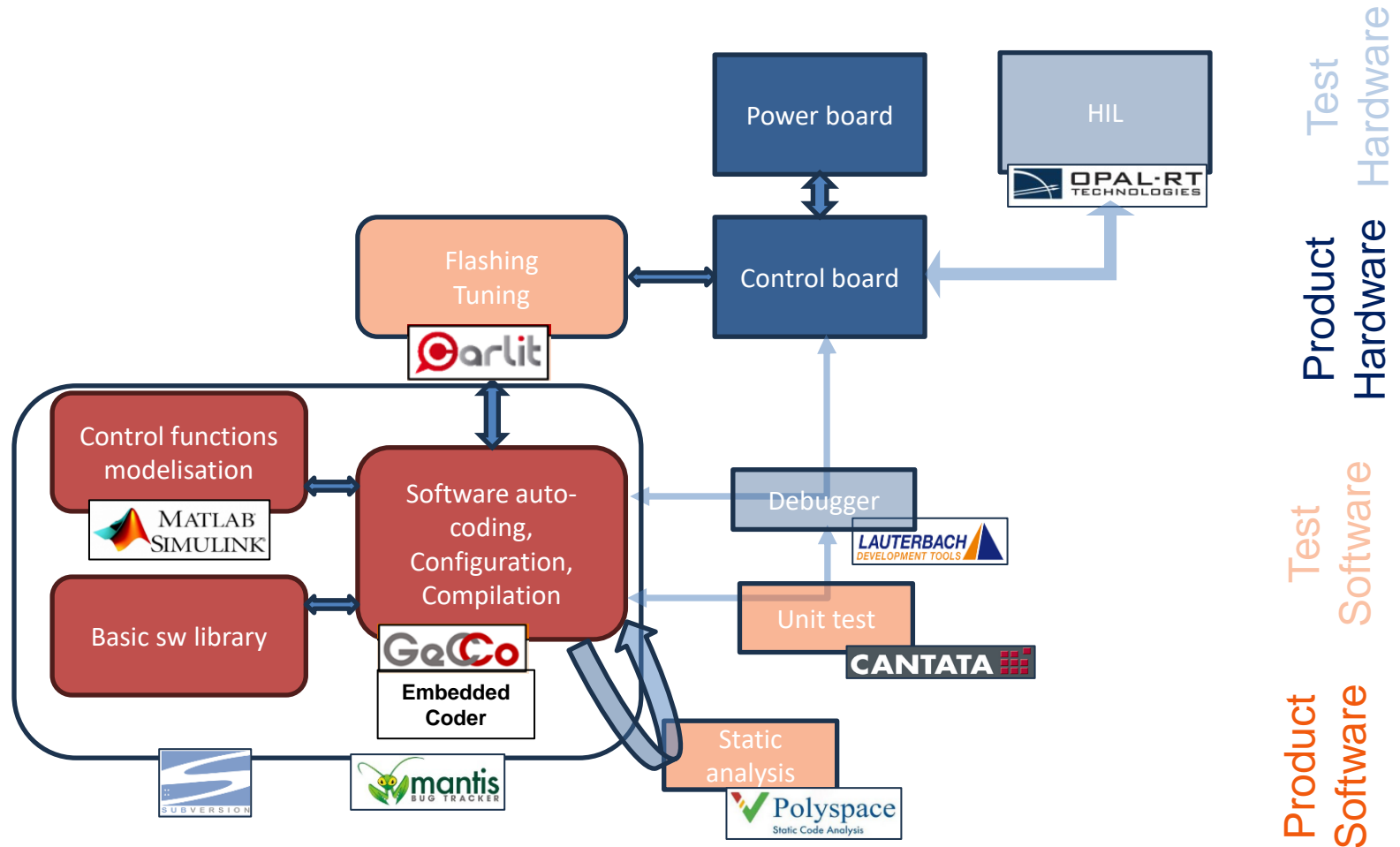

- A team of experts (7 people) covers the domains:
 - Software architecture
 - Basic Software
 - Diagnostic & communication (CAN, XCP, UDS...)
 - Application software
 - Software integration
 - Software quality
 - Experience in automotive field
- Ressource Allocation during Kick-Off meeting

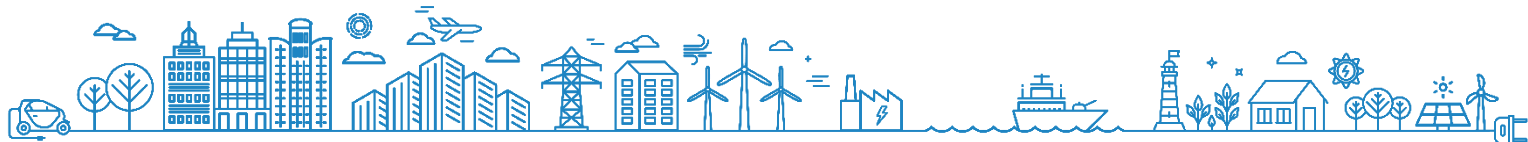

- Embedded software for Cirtem products
(C-language, manual or auto – Assembler)
- GUI software for Cirtem products
(Codesys)
- Software tools
 - For development (Gecco – Java, python, matlab)
 - For tuning, reprogramming, industrialisation, SAV
(Carlit – QT C++)

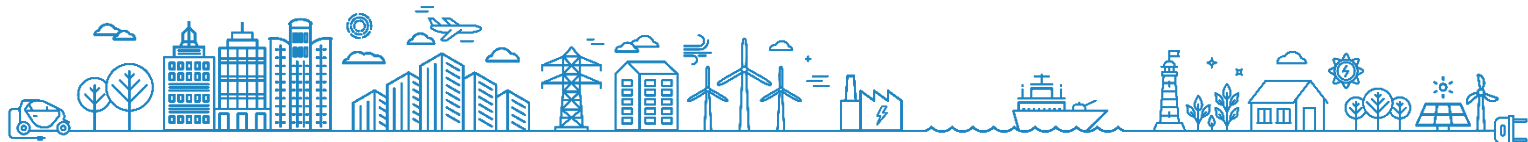

Architecture

Reversible AC-DC et DC-DC
LF, HF Isolation or transformerless
Hybridization of storages

Control

Real time regulations
Sensorless motor driving
Hybridization
Regenerative systems

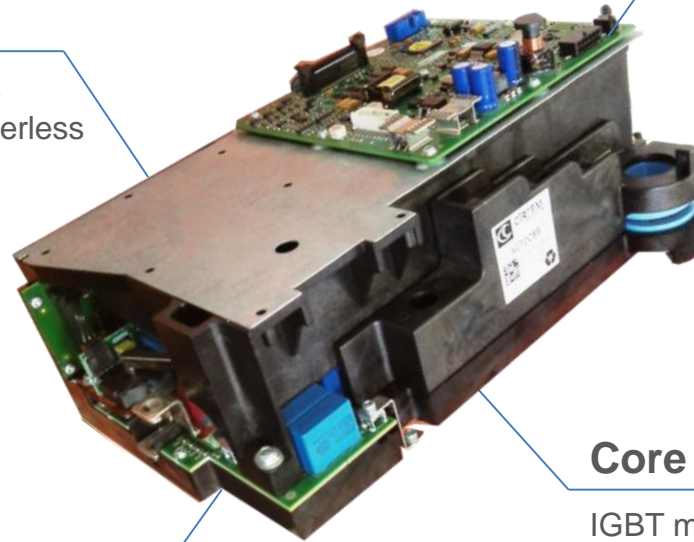

Ranges

Low voltage from 50V to 1500V
High voltage up to 50kV
Power from 1kW to 10MW
High speed up to 50 000 rpm

Core technologies

IGBT modules & MOS
SiC & GaN
Multilevel technologies
Planar transformers
Air or liquid cooling

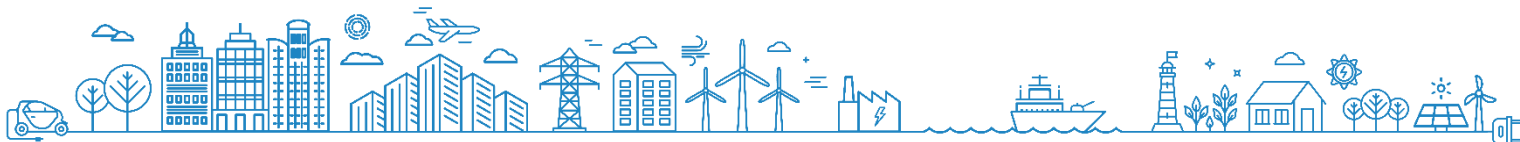

Test means

From simulation to physical test benches

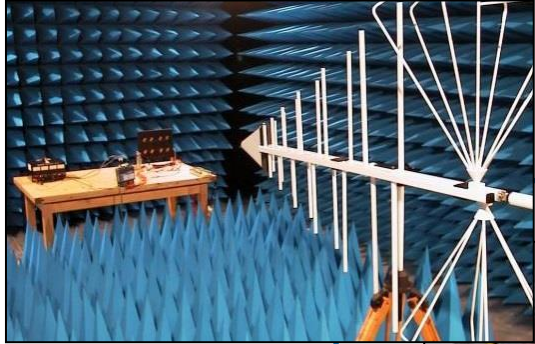

EMC Lab
ACEMIP

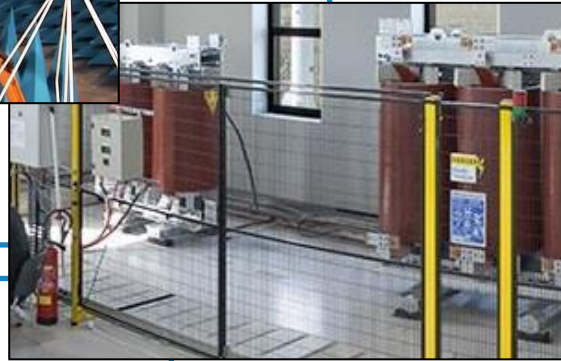

Test platform
150 kVA - 3 MVA

HIL bench
Opal RT



Motor bench
Electrical 200 N.m

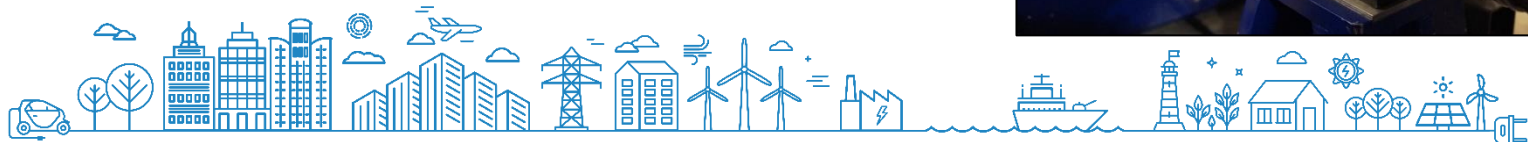
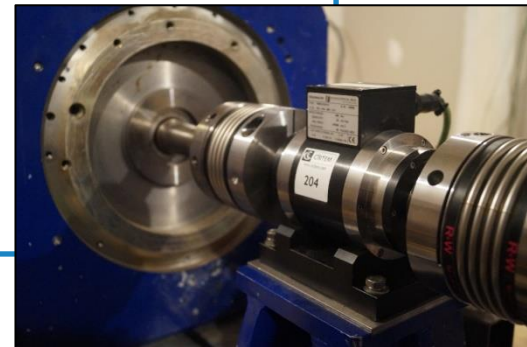

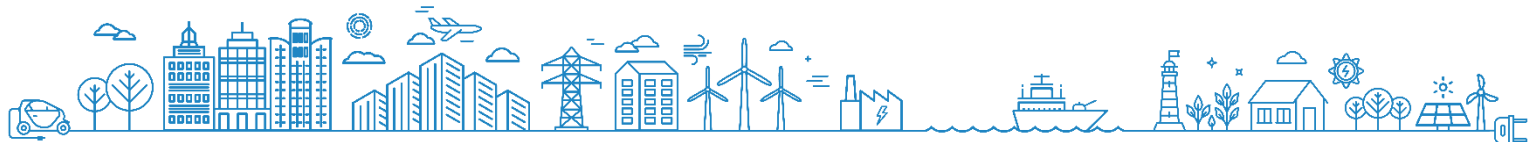

Manufacturing

Strong investment in power electronics

SMD LINE

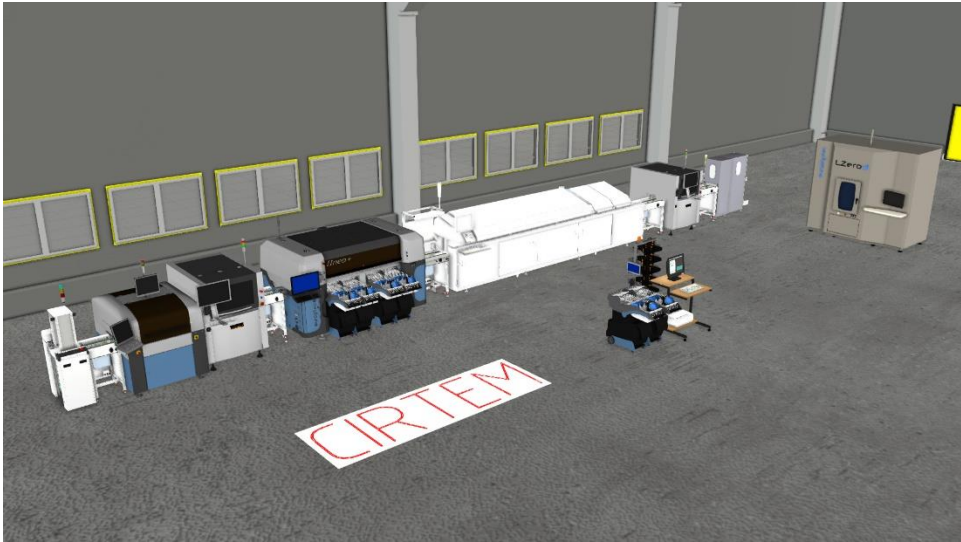

WAVE SOLDERING LINE



Manufacturing

Strong investment in power electronics

SMD LINE

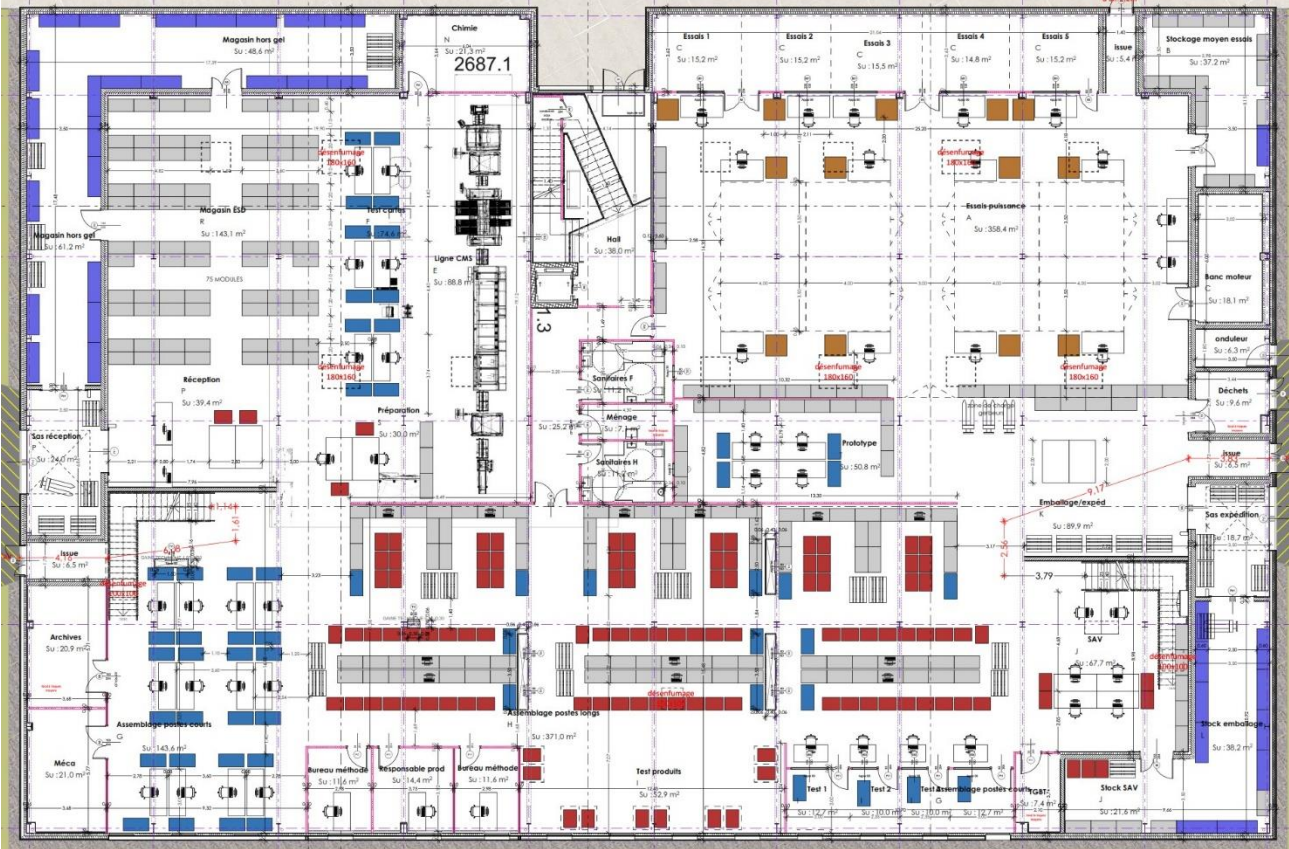

Products

Innovation – Development – Manufacturing

INVERTERS – MOTOR DRIVES

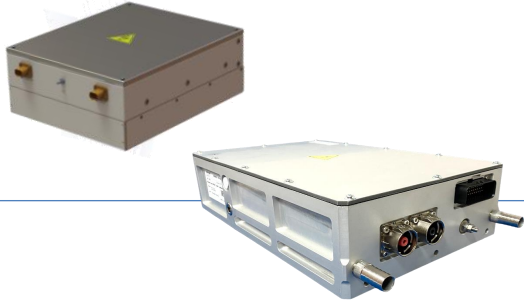

PDU



DC/DCs



CIRTEM develops and manufactures innovative Power Converters for optimized electrical systems:

- ✓ Development on specification with latest technologies
- ✓ Off the shelf product customization
- ✓ Built to print manufacturing

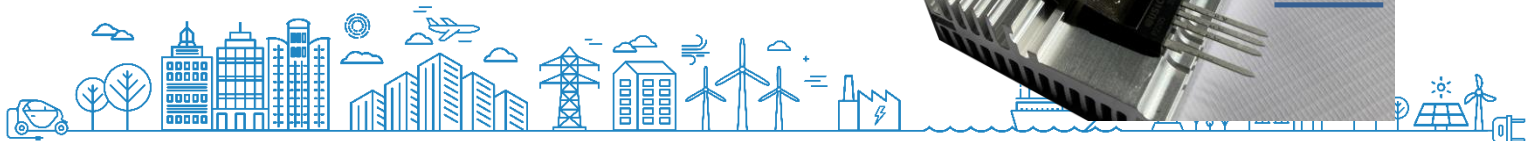



Mobility

AUTOMOTIVE PRODUCTS

CIRTEM PRODUCT FOOT PRINT

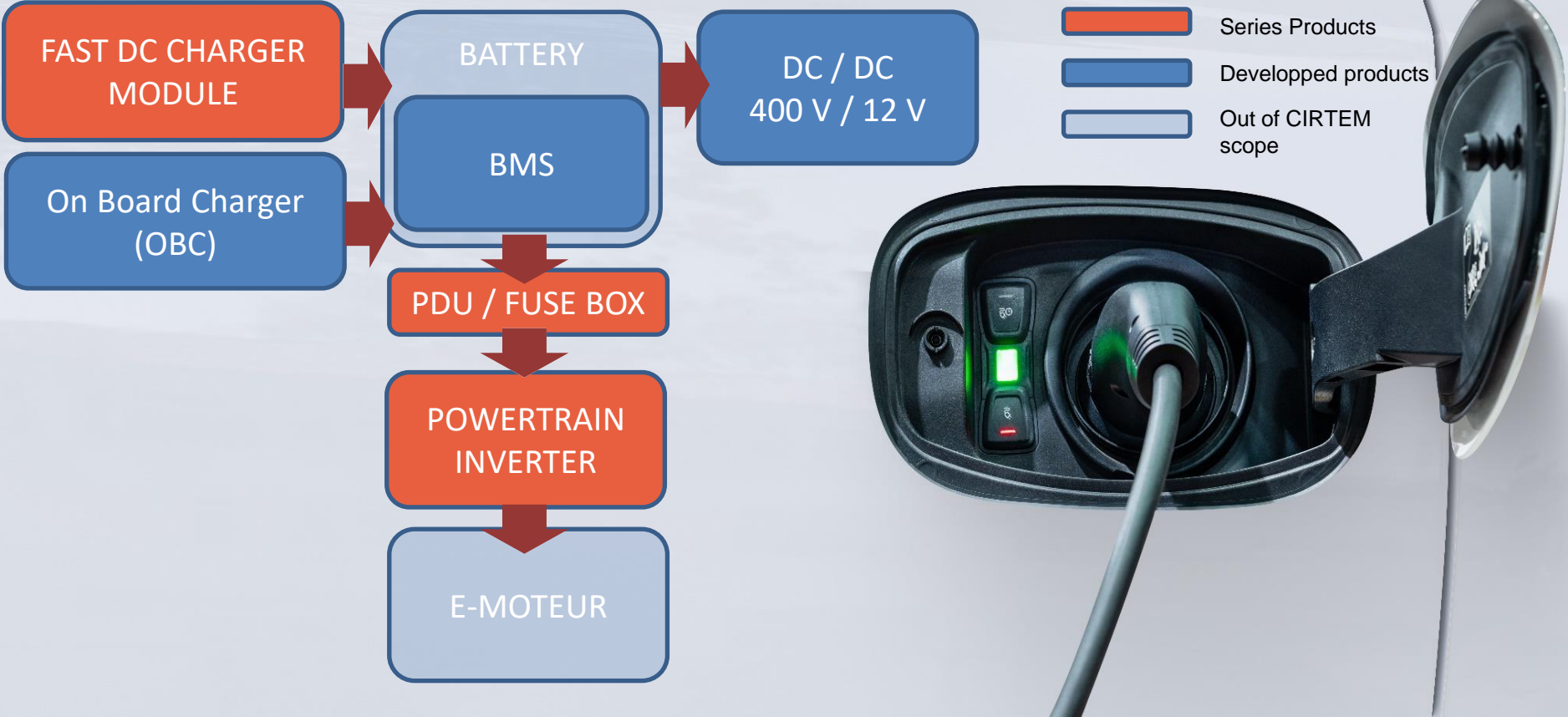

CIRTEM EV Powertrain Inverter

Serial production 11 000 parts produced

- ▶ **3-phase IGBT motor drive** for permanent magnet synchronous motor
- ▶ **50 kW / 450 VDC max**
- ▶ Specs :
 - 450 V DC battery / 170 A by phase
 - Liquid cooling
 - 2 CAN buses

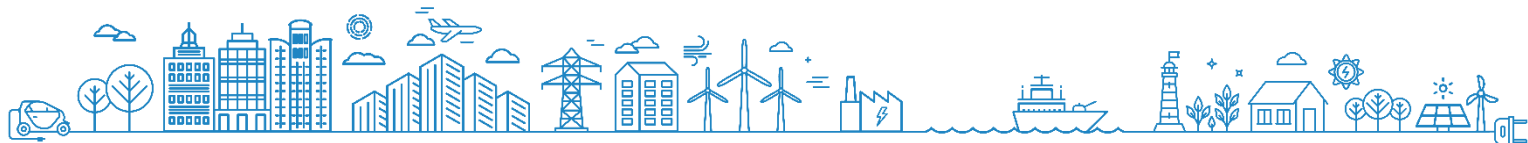
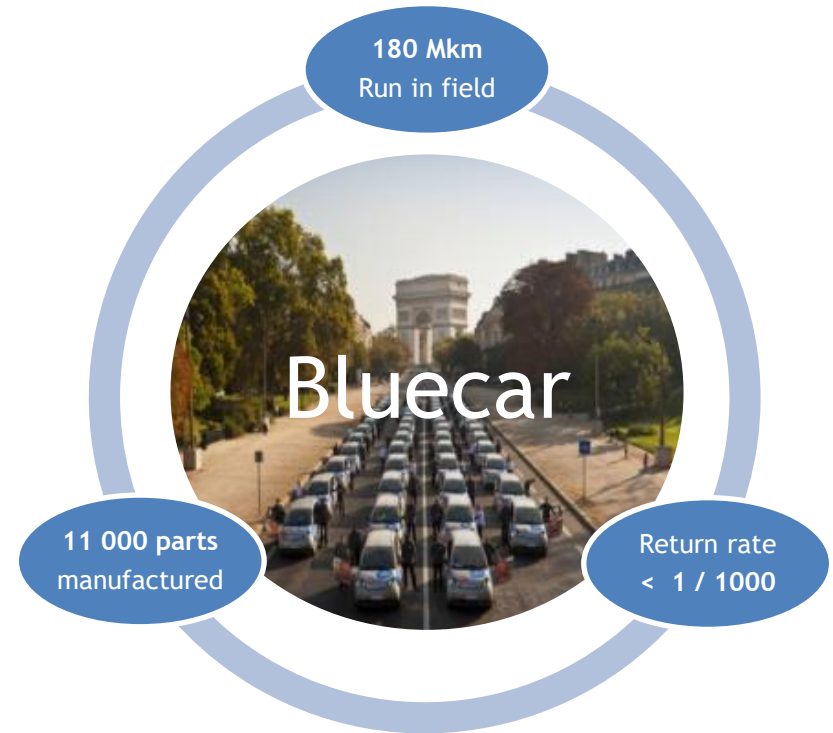



Electron II (GRUAU)

Inverter 70 kW_{nom}

- For synchronous motor (MSAP)
- 3-Phase IGBT inverter
- μ C control
- Water cooled
- Max Power 90 kW
- U_{dc} max 450 V

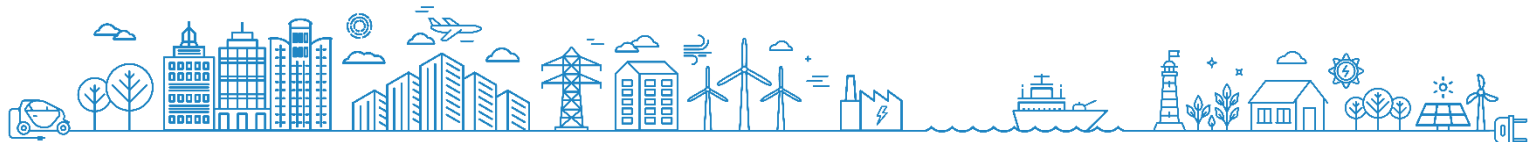

Electrical Motor Controller 150 kW EVI160A



Main Features

- Dedicated to permanent magnet motor
- 3-phase inverter with IGBTs
- Max input voltage: 450 VDC
- Motor current rms: 305A (605 A / 30 sec.)
- Power : 150kW (200kW / 30s)
- Torque or speed control
- Control & Monitoring: CAN2.0 bus
- Water cooling
- Waterproof case IP65
- Fundamental switching frequency: 1000 Hz max
- Braking recovery management
- Bootloader for field upgradeable firmware
- Sensorless control or Position sensor (SinCos sensor by default)

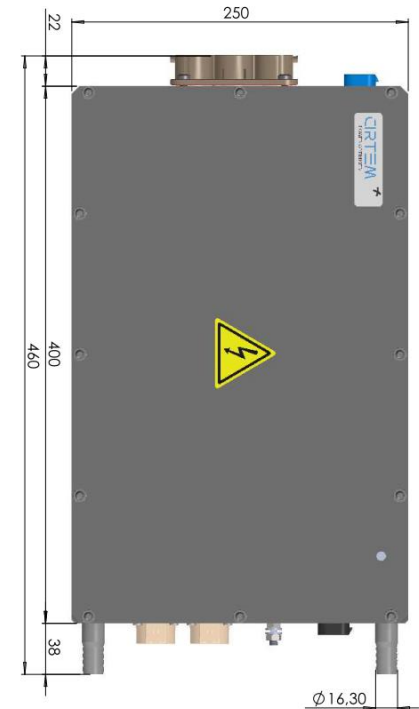
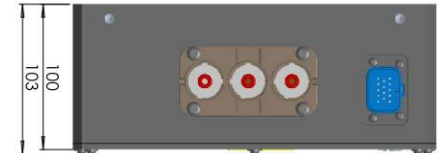

48V Inverter

B-sample validated inverter

VDC : 80V max
I_{rms}: 600 A max
F(Hz): 1000 Hz

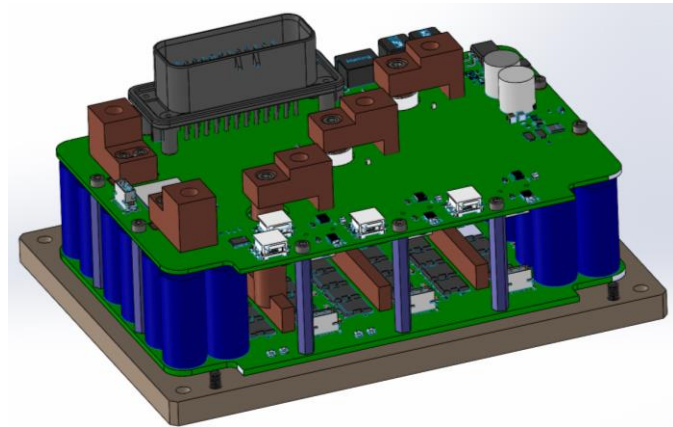
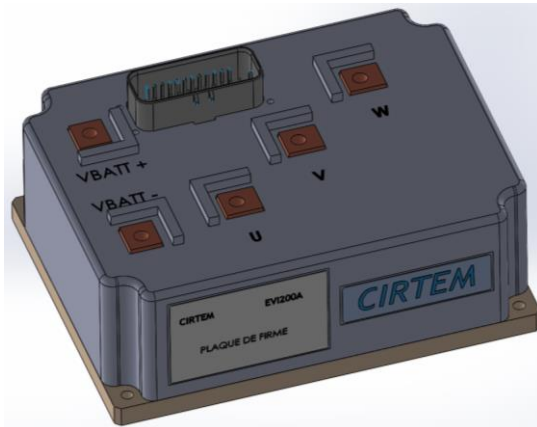
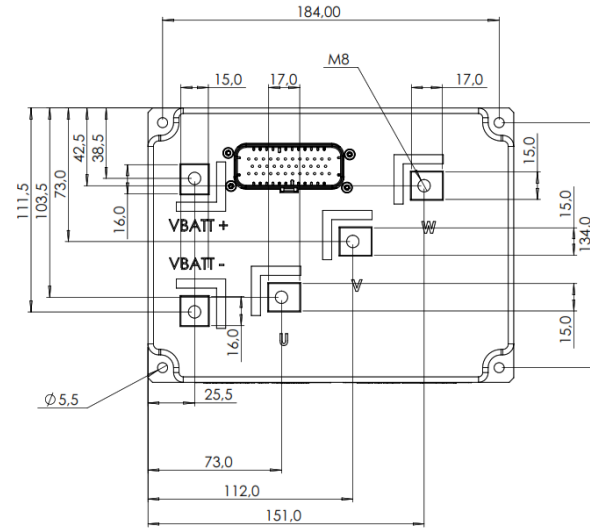



Blue Bus (Bolloré) & Retrofit operations

Battery charger 90 kW

- Reversible DC/DC reversible DC-DC
- IGBT interlaced leg chopper
- μ C control
- Liquid cooling
- Power 90 kW
- Udc max 750 V



Direct Current Connection Unit

- eBus Smart Junction box
- Max input voltage: 800 Vdc
- Max output current: 300 Adc
- EMC filter integrated on HV connections

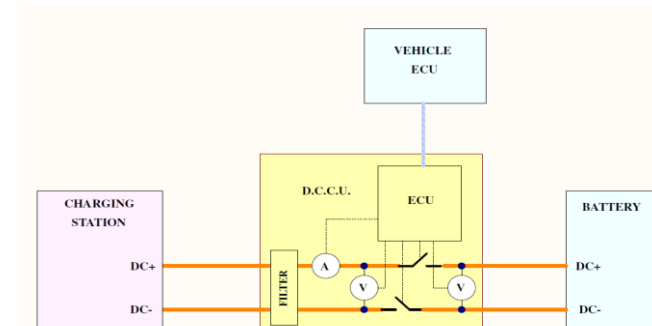
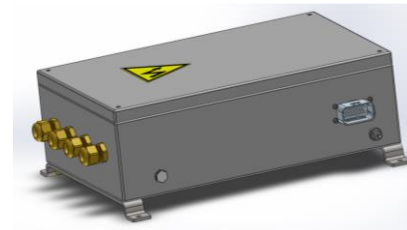

HV boxes & Battery boxes

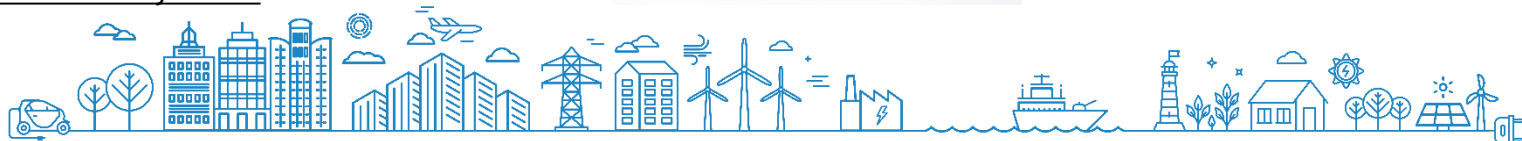



RENAULT (Client) – Vitesco (Partner)

CIRTEM is designing the Onboard Charger for 2026 Renault Vehicles

11 kW three phase integrated in the so called “ONEBOX” integrating Powertrain Inverter & DC/DC

**CIRTEM is in charge of building prototypes for 2026 Renault
HEV & Electric vehicles**

In a cooperation with VITESCO who undertakes serial processes not available at CIRTEM

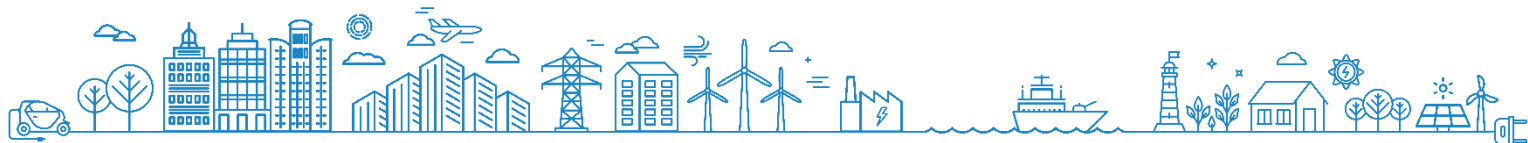

DESIGN & SERIES PRODUCTION

EV CHARGER POWER MODULE

- Serial production of 25 kW charger modules for a world-class industrial group for energy distribution

SHIP PROPULSION & ENERGY BOX

- Serial production for 300 p/y

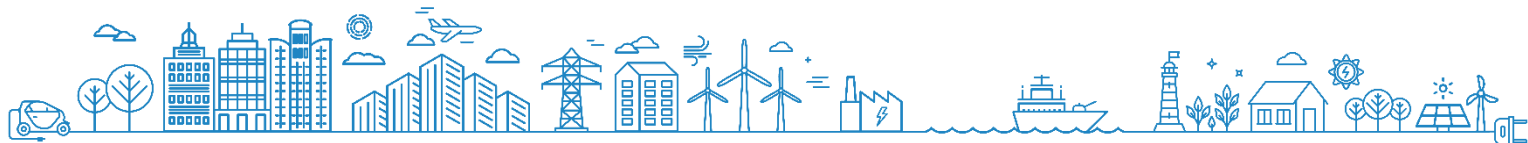



SMART GRIDS



ESS 1,2MVA/1,5MWH

Location: SCLE – Toulouse, France

Inverters: Smart AC – 3 cabinets 400kVA

Coupling: No

Battery: 650 to 820V

Mains: High Voltage 20kV with transformer

Missions:

- Grid regulation
- Site consumption management

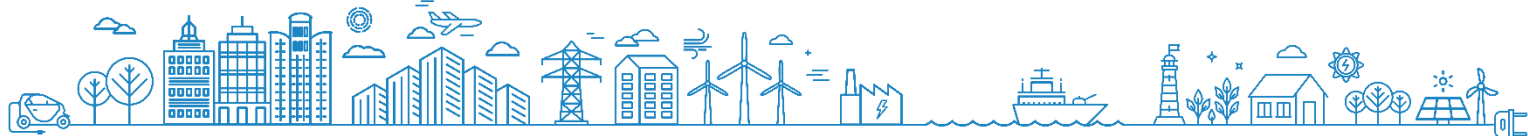

ESS 2, 4 MVA / 4,5 MWh



Location: Alata – Corsica (France)

Inverters: Smart AC – 6 cabinets 400kVA

Coupling: with 3rd party inverters

Battery: 710 to 880 V

Grid: High Voltage 20 kV with transformer

Missions:

- Renewable energies smoothing
- Grid injection with contractual pattern
- 1000 houses supply



SMART GRID ON DC BUS



Location: SCLE – Toulouse, France

Converters:

- Smart AC TL 125kVA (97,7%)
- DC-DC for Battery LG 33kW (99,4%)
- DC-DC for PV with MPPT 33kW (99,4%)
- Drives for Flywheel 10kW (99%)

Coupling: DC bus 650V

Mains: 400 V_{AC} without transformer to the grid

Missions:

- Renewable energies smoothing
- Grid injection with contractual pattern



WEB : <http://www.smartgrids-cre.fr/index.php?p=smart-zae>

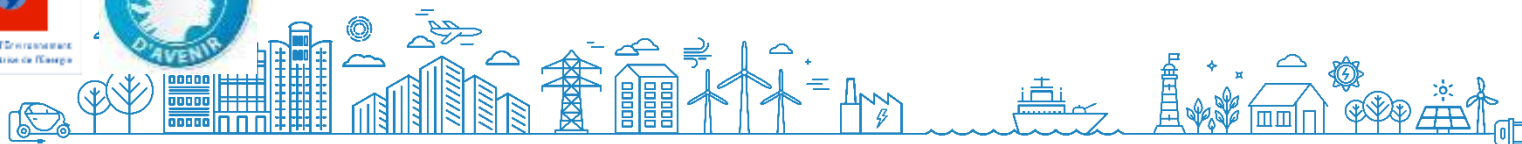

Grid balancing:
Disturbances between SNCF (Railway) & RTE grid : **max. 1,8%**

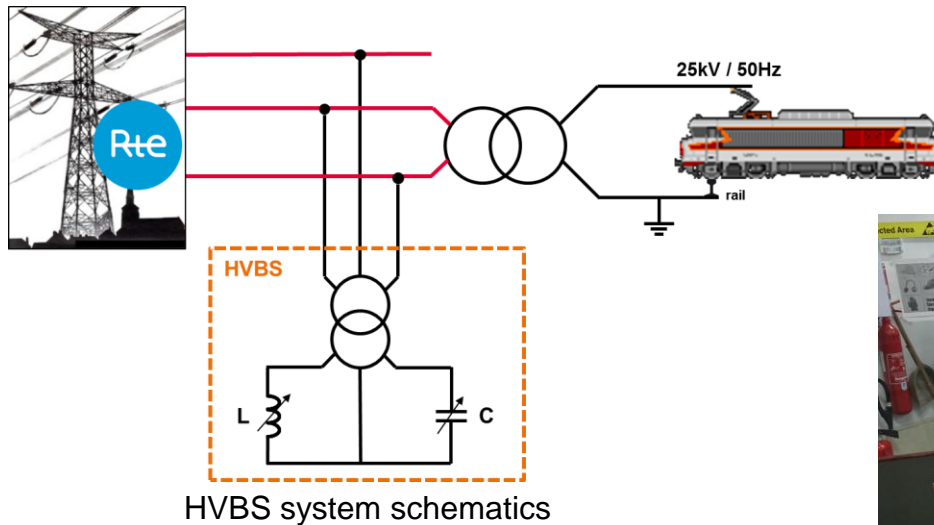

55 chained modules (66kVAr / 400V each) Standard voltage (20 kV) →
3,3MVar ind/cap

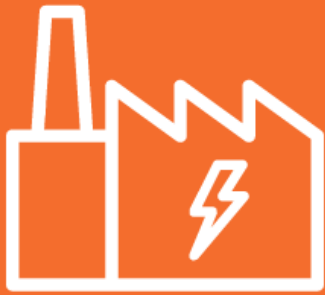

Industry

Our products for industry



Power supplies for industrial processes
From 10 to 1000 A

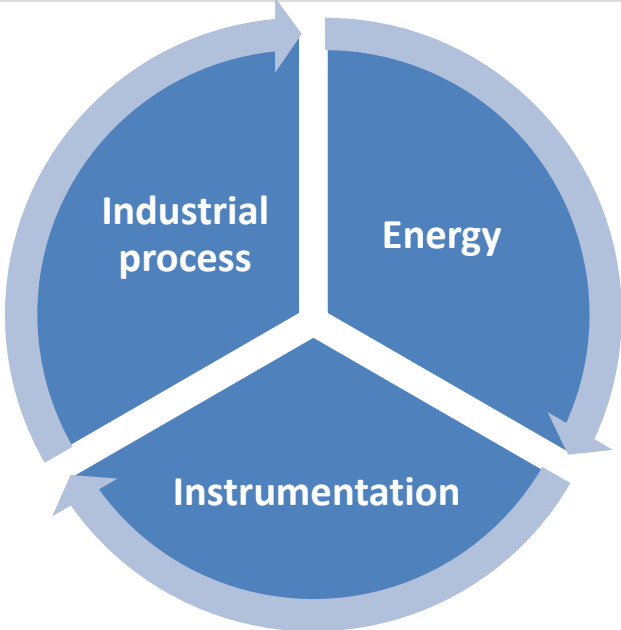

Battery discharger
120 kW / 200 kW



Static switch
up to 450 A



Micro Arc Oxidation power supply

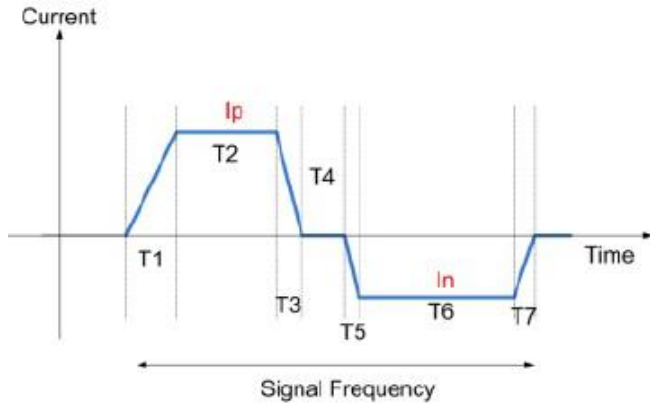

100 kW power supply

- Fully configurable current profile
- 250A / 1000Vmax / 100 to 400Hz
- Up to 4 units to reach 1000A / 400kW
- Rise time 1000A/ms max
- Liquid cooling
- Modular design for easy maintaining

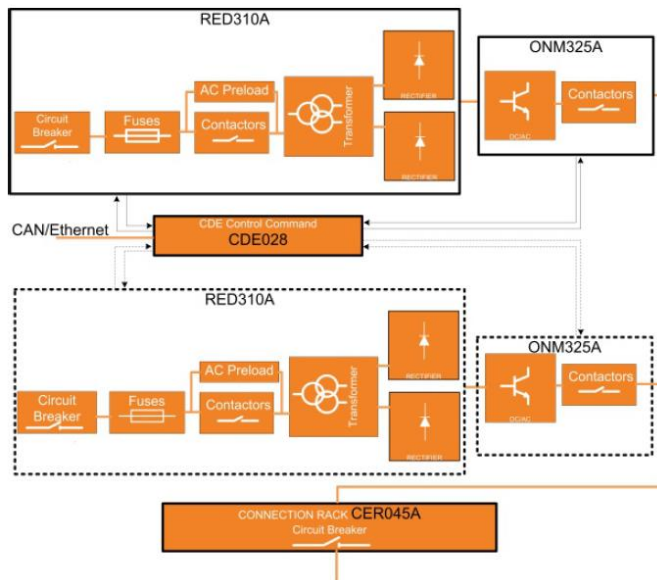

Ozone generator power supply



Power supply 140kW

- Power supply for resonant load 367A max
- +500V / -500V
- 5,5kHz to 10kHz
- Liquid cooling

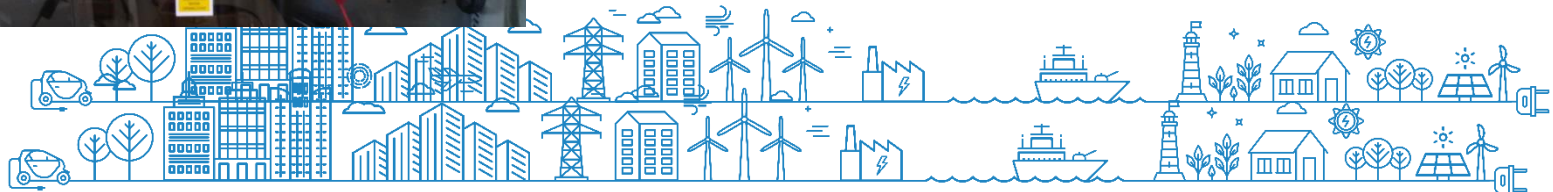
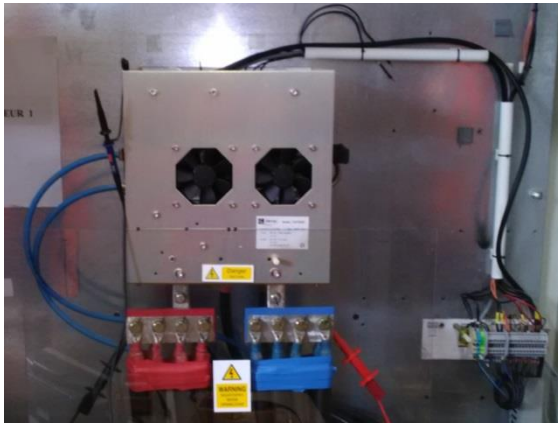

Power supply for particle accelerator

LHC superconducting magnets power supply

$\pm 10V/\pm 600A$ - rms ripple: 7mV - few ppm

444 power supplies produced in one year (2005)

Italian partner

Contract value: 6,5 M€

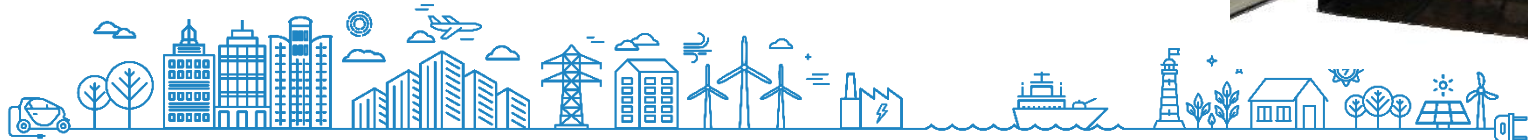



Contact

Marketing & Sales Director

Thibaut KEIN

 +33 788 058 205

 t.kein@cirtem.com



www.cirtem.com